

# SHURE®

Shure Brothers Incorporated  
222 Hartrey Avenue  
Evanston, IL 60202-3696 U.S.A.

## AMS4000 AND AMS8000 Installer's Manual

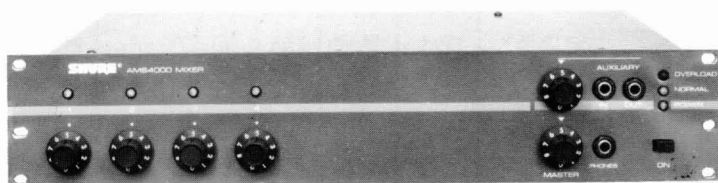

AMS4000



AMS24



AMS22



AMS26



AMS28

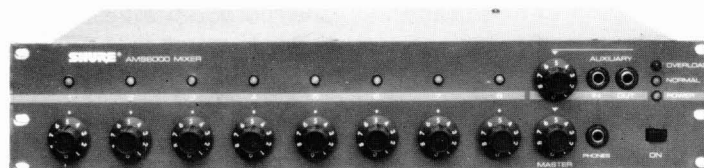

AMS8000

The Shure Automatic Microphone System [AMS] turns microphones on and off [with automatic gating], greatly reducing the reverberant sound quality and feedback problems often associated with the use of multiple microphones. The special AMS microphones are gated on only by sounds arriving from the front within their acceptance angle of 120°. Other sounds outside the 120° angle, including background noise, will not gate the microphones on, regardless of level. In addition, the AMS adjusts gain automatically to prevent feedback as the number of "on" microphones increases.

The resulting sound is clearer than that of conventional multiple microphone speech reinforcement and recording systems—and free of the clipped and missed words, clicks and pops, and noise pumping often associated with other "automatic mixer" systems. Besides its major advantages of simple setup and unmanned operation, the Automatic Microphone System operates over an extremely wide dynamic range without the possibility of threshold-setting misadjustments.

AMS Mixers are supplied in 4- and 8-channel configurations [Models AMS4000 and AMS8000], each housed in a single 3½-inch rack-mount package. Both contain logic terminals [for channel muting, override functions, and gating indications], and link circuitry for expansion to as many as 200 linked channels.

### AMS Features:

- Reliable, quick-acting, noise-free gating—virtually insensitive to changes in sound source loudness or distance
- Smooth pleasant-sounding turnon and turnoff characteristics
- No threshold settings to misadjust
- Front-panel microphone channel gain controls and Master control operate as in conventional mixers
- Selectable hold time keeps microphones on during short pauses
- Preset or adjustable Off-Attenuation control for unobtrusive gating
- Automatic gain adjustment as additional microphones gate on
- Wide, flat frequency response and low distortion up to +18 dBm output
- Logic inputs and outputs enhance system versatility
- Linking capability for systems of as many as 200 microphones and 25 mixers
- LED indication of gating operation and output level
- Automatic muting prevents annoying thumps and loudspeaker damage when unit is turned on and off
- Four or eight special microphone inputs [for use **only** with AMS microphones] use standard two-conductor shielded cables and three-pin connectors
- Balanced output switchable to line or microphone level
- Front- and rear-panel unbalanced Aux inputs and outputs
- Front-panel headphone monitor jack
- Direct [non-gated] outputs available from individual microphones
- Underwriters Laboratories Listed and Canadian Standards Association listed as Certified

### IMPORTANT

Shure AMS4000 and AMS8000 Mixers are designed for use only with Shure AMS Condenser Microphones. Conventional condenser or other microphones will not operate properly with the AMS4000 and AMS8000.

# TABLE OF CONTENTS

General	1
Specifications	3
Connections, Controls and Indicators	4
Microphone Placement	6
Typical Applications	6
Conference Room	6
Church	6
Courtroom	6
Legislature	6
Logic Functions	8
Cough Button	8
Chairperson-Controlled Muting	8
Disabling the Gating Function (Bypass)	8
Remote Channel-On Indication	8
Loudspeaker Muting	8
“Filibuster” Mode	9
Preventing Room Noise Modulation	9
Microphone Lock-On	9
Diode Isolation of Logic Controls	9
External Logic Devices	9
15-Volt CMOS	10
Digital Controls or Microcomputers	10
Wireless Microphones	10
Direct Out Gating	10
Controlling Non-AMS Microphones	11
Operating Hints	11
Phasing	11
Microphone Muting	11
Grounding	11
Internal Wiring Modifications	11
Troubleshooting	15
Appendix I: Effects of Acoustic Environment on Gating	16
Room Noise	16
Reverberation	16
Talker Distance and Angle	16
Reflective Surfaces	16
Appendix II: Theory of the Shure Automatic Microphone System	16
Appendix III: AMS Mixers and Conventional Microphones	17

## WARNING

Voltages in this equipment are hazardous to life. Refer all internal wiring modifications and servicing to qualified service personnel.

## SPECIFICATIONS

**Output Level** [at full gain, 1 kHz, one channel gated On, Off-Atten at -15, with AMS26 probe microphone, output terminations: Line 600Ω, Mic 150Ω, Aux 50k, Direct 50k, Phones 200Ω]

INPUT	OUTPUT					Input Clipping Level at 1 kHz
	Line	Mic	Aux	Direct	Phones	
Microphone Input Sensitivity [72 dB SPL in] (+18 dBm)	+15.8 dBV	-34 dBV	+17 dBV	-56 dBV	-4 dBV	128 dB SPL
Aux Input Sensitivity [-22 dBV in]	+15.8 dBV	-34 dBV	+17 dBV	—	-4 dBV	+7 to +20 dBV*

\*Depending on Aux control setting.

### Frequency Response

Aux Input to Outputs: 30 to 20,000 Hz,  $\pm 2$  dB  
 Mic In to Outputs: 70 to 20,000 Hz,  $\pm 2$  dB [controlled low-frequency rolloff below 50 Hz]

### Aux Input Impedance

70k or greater, unbalanced [designed for use with less than 10k source impedance]

### Outputs

OUTPUT	IMPEDANCE		Output Clipping Level
	Designed for Use With	Actual [Internal]	
Mic	150Ω balanced lines	1Ω	-34 dBV
Line	600Ω balanced lines	150Ω	+15.8 dBV [+18 dBm]
Aux	10k or greater	2.2k	+17 dBV
Direct	10-50k unbalanced mic circuit	1k	0 dBV
Phones	200Ω	2.2k to tip, 2.2k to ring	-4 dBV

### Hum and Noise

Equivalent Input Noise: 27 dB SPL, A-weighted, with AMS26 probe microphone

Output Noise: -62 dBV [master up], -88 dBV [master down] [300-20,000 Hz, input controls down, Off-Atten at -15]

Output Hum and Noise: -58 dBV [master up], -79 dBV [master down] [20-20,000 Hz, input controls down, Off-Atten at -15]

### Distortion

THD 0.35% or less, 30 to 20,000 Hz at +15 dBm output; IMD 0.5% or less up to +15 dBm output

### Phase

Positive pressure on AMS microphone diaphragm produces positive voltage on pin 2 of Line/Mic balanced output with respect to pin 3, tip of Aux output, and tip and ring of Headphones output, and negative voltage on tip of Direct output. Aux output is in phase with Aux input.

### Gating

Attack Time: 4 msec  
 Hold Time: 0.5 or 1.0 sec [switchable]  
 Decay Time: 0.3 sec after Hold interval

### Off-Attenuation

Fixed: -15 dB

Variable:  $-\infty$  to -8.5 dB

[Single mixer; attenuation increases as additional mixers are linked]

### Overload and Shorting Protection

Shorting the inputs or outputs, even for prolonged periods, will cause no damage; mic inputs will not be damaged by signals up to 3V; aux inputs will not be damaged by signals up to 10V

### Logic Terminals [all specifications referenced to Logic Ground terminals]

Inputs [Override, Mute]

High [inactive]: Greater than 1.9V [5.0V typical] [no input current with 5.0 to 20V applied]

Low [active]: Less than 1.9V [0V typical] [sources 80 μA when grounded]

Min/Max Applied Voltage:  $\pm 20$ V

Outputs [Gate]

High [inactive]: 5.0V in series with 10k resistance [sources 0.2 mA with 3.0V output] [min/max applied voltage: -0.5 to +15V]

Low [active]: Less than 0.5V sinking [100 mA max]

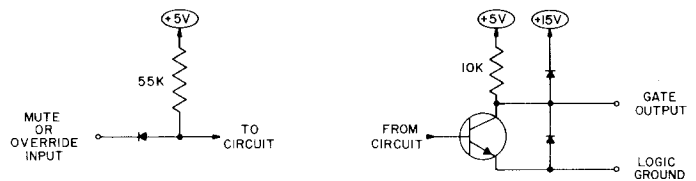

### LOGIC EQUIVALENT CIRCUIT DIAGRAM

FIGURE 1

### Operating Voltage

105-132 Vac, 50/60 Hz, 20W [fused internally]. Can be rewired for 210-264 Vac operation [see 240V Operation]

### Temperature Range

Operating: -29° to 57°C [-20° to 135°F]

Storage: -29° to 71°C [-20° to 160°F]

### Dimensions

See Figure 2

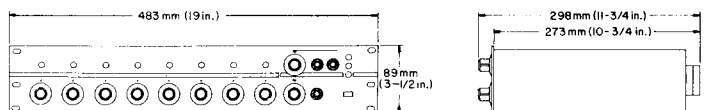

### OVERALL DIMENSIONS

FIGURE 2

### Weight

AMS8000: 6.6 kg [14 lb 8 oz]

AMS4000: 5.8 kg [12 lb 13 oz]

AMS8000 [packaged]: 7.8 kg [17 lb 4 oz]

AMS4000 [packaged]: 7.1 kg [15 lb 9 oz]

### Certifications

Listed by Underwriters Laboratories, Inc.; listed by Canadian Standards Association as Certified

## CONNECTIONS, CONTROLS, AND INDICATORS

[Paragraph numbers that follow refer to pictorial views on inside back cover.]

1. **Microphones:** The Shure AMS Condenser Microphones are designed specifically for use with Shure Automatic Microphone Systems, AMS4000 or AMS8000 mixers. **Do not attempt to connect AMS microphones to standard phantom-powered or standard non-phantom-powered inputs; they will not function properly.**

The AMS microphones, in conjunction with the special circuitry of the AMS mixers, uniquely discriminate between desired sounds that originate within their 120° front acceptance angle and all other sounds. The desired sounds from the front of a microphone are detected and cause the microphone to be gated on, transmitting its signal to the mixer output. Sounds outside the acceptance angle will not gate the microphone on. When a microphone is "on" [accepting signals], it operates like a cardioid microphone [or like a hemi-cardioid in the case of low-profile microphones]. Each AMS microphone operates completely independently in analyzing its own sound field and deciding whether a sound source is within the front acceptance angle.

Among available microphones are: a low-profile surface-mount model [AMS22], a gooseneck model for permanent mounting [AMS24], a probe model [AMS26] with a front pop-filter grille, and a lavalier model [AMS28]. Due to the reinforcement of sound waves from the adjacent boundary surface, the sensitivity of the surface-mount model is twice as high [6 dB more] as that of the probe model. The gooseneck model is supplied with a cable, but less connector.

The microphone connector is a standard 3-pin professional audio type [XLR]. Under most circumstances, lengths of 150 meters [500 ft] or greater of good quality 2-conductor shielded microphone cable can be used as extensions between the microphone and the AMS mixer microphone input. The same conductor must be wired to the same numbered pin at both ends of the cable to ensure proper functioning of the units. The shield should be connected to pin 1 at both ends of extension cables. Good practice dictates that microphones and extension cables be grounded only to the AMS mixer chassis ground.

2. **Microphone Inputs:** The AMS mixer is supplied with either four or eight microphone inputs per unit. The microphone inputs are designed for use only with Shure AMS microphones; the Mixer will not operate with other microphones; and Shure AMS microphones will operate properly only with AMS mixers. The microphone input connector is a female XLR type.
3. **Microphone Channel Gain Control:** When set to the "0" position [detented counterclockwise], the microphone is not permitted to gate on. Turning the control clockwise from this position permits the microphone to gate on either for sounds within its acceptance angle or by a connection to the Override logic terminal [see description of Logic Terminals below].

The Microphone Channel Gain control does not affect the Direct Output level unless a jumper change has been made for post-fader output as described in Paragraph 4 below.

4. **Direct Output:** This provides a non-gated microphone-level signal from the microphone. This output behaves like a conventional cardioid high-impedance microphone output. It can be converted to balanced low impedance using a line matching transformer [Shure A95U]. An **unbalanced** low-impedance microphone level can be obtained by loading with a 100-ohm resistor [connected tip to sleeve].

The ¼-inch phone jack is supplied wired pre-fader so that the output is not affected by the position of either the individual Channel control or the Master control, even when the Channel control is in the counterclockwise detent ["0"] position.

Each channel can be wired post-fader by moving a jumper on the input module board [see section on Internal Modifications for details]. This change causes the level at the Direct Output to follow the setting of the Channel control.

5. **Channel LED Indicator:** A yellow LED indicator above the Channel control lights when the microphone is gated on. The status of the Direct output is not related to the LED.
6. **Hold Time:** This switch determines how long the microphone stays on after the user stops talking. This delayed turnoff bridges pauses in speech and reduces unnecessary gating action. The 0.5-second position minimizes microphone on-time, while the 1.0-second position bridges longer pauses.  
  
For special applications, the 1.0-second position can be increased to as long as 2 seconds by inserting a resistor [see Internal Modifications section for details].
7. **Off-Attenuation:** This switch determines the attenuation of microphones that are not gated on. It is unnecessary for "off" microphones to be totally off to gain the benefits of automatic mixing. Keeping them slightly on at all times contributes to smooth unobtrusive gating action.

The -15 setting of the Off-Attenuation switch is recommended for most applications. The Variable setting allows continuous adjustment of the Off-Attenuation from minus infinity to -8.5 dB [-8 setting] by the screwdriver-slot adjustment directly above the switch. [See sections on Link Jacks and on Theory of Operation for further information on Off-Attenuation.]

8. **Power Cord:** A 3-conductor cord and grounded plug designed for connection to 120 Vac, 50/60 Hz outlets only. To modify the unit for 240V, refer to the section on Internal Modifications.
9. **On-Off Switch:** Push-button switch on the front panel turns the power to the AMS mixer on and off.
10. **Power-On LED:** A green LED on the front panel lights when the power is on.
11. **Normal LED:** A yellow LED on the front panel above the Power-On LED begins to turn on when the line and aux output levels are above approximately -20 dBV [100 mV].
12. **Overload LED:** A red LED flashes when the

Line/Mic, Aux, and Phones outputs approach clipping. If this light flashes on, turn down the Microphone Channel controls of the channels in use or turn down the Master control until the light stays out.

13. **Aux Input:** A ¼-inch unbalanced phone jack input on both the front and rear panel of the AMS mixer, suitable for Aux level and line level sources, such as tape recorders or players or conventional mixers. This non-gated input is mixed with the combined microphone signals to appear at the Line/Mic, Aux, and Phones outputs.
14. **Aux Control:** The position of this control determines the level of the Aux Input.
15. **Master Control:** The position of this control determines the level of the combined microphone and aux signals at the Line/Mic, Aux, and Phones outputs.
16. **Line/Mic Output:** This male XLR audio connector has switch-selectable levels: either low-impedance balanced microphone level or 600-ohm balanced line level. This output provides the combined gated microphone and non-gated aux input signals.
17. **Aux Output:** The ¼-inch phone jack outputs on the front and back panels are intended for unbalanced Aux or line level loads. This output also provides the combined gated microphone and non-gated aux input signals.
18. **Phones Output:** This ¼-inch phone jack is suitable for most stereo or mono headphones with 2- or 3-circuit phone plugs. The signal at this output is identical to that at the Line/Mic output.
19. **Logic Terminals:** These four screw terminals are built into a female barrier block module that plugs into a male connector on the rear panel below the Direct Output jacks (Figure 3). The barrier block's plug-in design ensures proper placement and simplifies terminal wiring by eliminating the need for soldering. Connections to these terminals are not necessary for basic AMS operation, but allow the AMS mixer to perform additional functions. Unshielded wire or multi-conductor cable is adequate for the connectors.

The logic levels are nominally 0 volts (low) and 5.0 volts (high); they are directly compatible with standard 5-volt logic families (including CMOS and TTL).

**GATE OUT:** This terminal follows the channel gating and goes to logic "low" when the microphone is gated on. Sufficient current-sinking capability is provided to light externally powered LED's (see Logic Functions section for example).

**LOGIC GROUND:** The Logic Ground terminals of all channels are connected together internally and are distinct from the AMS audio ground. All logic ground connections should be made to these terminals. The power supply ground of external logic circuitry should be connected to the Logic Ground terminal of Channel 8 (or Channel 4 in 4-channel AMS mixers). To avoid switching clicks, do not interconnect the Logic Ground with the audio, chassis, or rack grounds.

**MUTE IN:** Applying a logic "low" to this terminal (from a logic gate or a switch closure to Logic Ground)

gates the channel off. The channel output drops to the level set by the Off-Attenuation switch. The Mute function dominates Override when both are simultaneously activated unless a jumper change is made so that Override dominates [see Internal Modification section for details].

**VERRIDE IN:** Applying a logic "low" to this terminal (from a logic gate or a switch closure to ground) forces the channel on. The mixer is supplied so that when both Mute (described above) and Override of a channel are activated, Mute dominates.

**Inhibit Function:** The Mute function can be altered to Inhibit by an internal jumper change for each channel [see Internal Modifications section for details]. After the change, a logic "low" at the Mute In terminal prevents the channel from gating on if it is off, but allows it to remain on if it is already on.

After the Inhibit modification, for certain specialized applications a logic connection can be made between a channel's Gate Out and its Mute In terminal.

**IMPORTANT:** To prevent high-frequency oscillation, never connect a channel's Gate Out to its Mute In unless the Inhibit modification has been made.

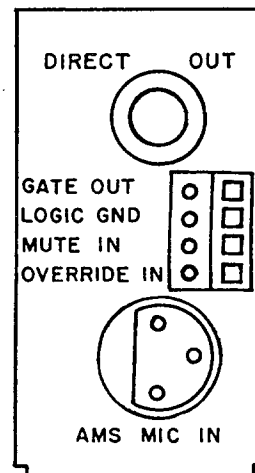

**REAR-PANEL CHANNEL PLATE  
FIGURE 3**

20. **Link Jacks:** These rear-panel ¼-inch phone jacks are used to link up to 25 AMS mixers together to provide an input capability of as many as 200 microphones. To link mixers, use short 1-conductor shielded cables with ¼-inch phone plugs on both ends. Plug a cable between the Link A Out jack of one mixer and the Link A In jack of the next mixer; **AND** plug a cable between the Link B Out jack of one mixer and the Link B In jack of the next. Leave open the Link In jacks of the first mixer in the chain and the Link Out jacks of the last mixer in the chain. Both the Link A and Link B jacks of each mixer must be connected: A Outs to A Ins and B Outs to B Ins. Use the Link jacks for linking only, not for audio inputs or outputs.

**IMPORTANT:** When using the logic terminals on

linked mixers, connect the Channel 8 Logic Ground terminals of each unit together. Switching clicks may result if this is not done.

When mixers are linked, the combined signals of all the microphones appear at the outputs [Mic/Line, Aux, and Phones] of ALL the linked mixers. Thus, you can take outputs from several mixers for a multiple feed.

However, an aux source connected to an AMS mixer is heard at the outputs of that mixer only, NOT at the outputs of linked mixers. For this reason, plug the aux source into the mixer providing the audio output. If multiple feeds are being used from linked mixers and it is desired that the aux source appear in all, parallel the aux source [using Y-adaptor cables] to the Aux inputs of all the mixers used for the multiple feeds.

The Master Gain control on each linked mixer controls the overall level at its own outputs of **all** the linked microphones and of its **own** Aux inputs. The Off-Attenuation controls and the Normal and Overload LED's operate in the same way—they control and show the status of the outputs from the mixer on which they appear. The Hold Time switch on each mixer affects only the microphones connected to that mixer.

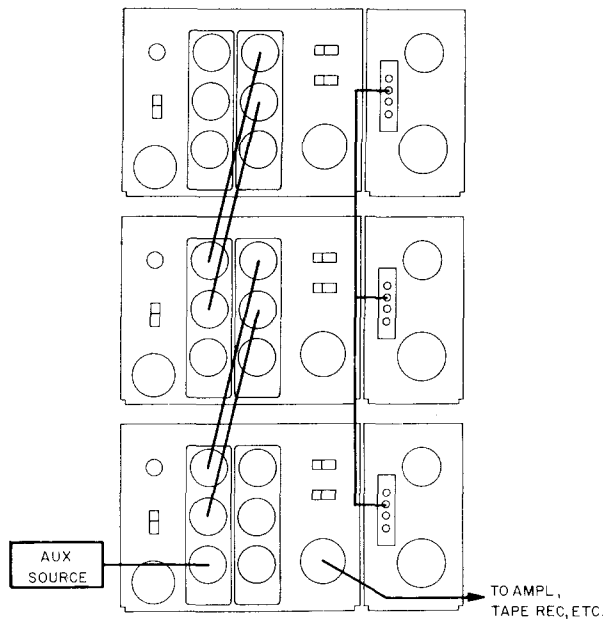

**LINKING MIXERS**  
**FIGURE 4**

**MICROPHONE PLACEMENT**

Use Low-Profile AMS22 Microphones on tables and desks; use permanently mounted Gooseneck AMS24 Microphones on tables, desks or lecterns; use Probe AMS26 Microphones on floor or desk stands or goosenecks; use Lavalier AMS28 Microphones where the talker must have freedom of movement.

Locate the microphones so that intended sources are within 60° of either side of the front of the microphone; that is, within the 120° acceptance angle [see Figure 5]. Sources of undesired sound should be located outside the 120° acceptance angle.

Use as few microphones as necessary to pick up everyone. The closer the microphones are to their sound sources, the greater the loudness of the sound system before feedback occurs. Each microphone should be at least 1 meter [3 ft] from the wall behind it, and at least 0.3 meters [1 ft] from objects behind it, such as large ashtrays or briefcases. When using AMS28 Microphones, avoid acoustic feedback from loudspeakers near the microphones.

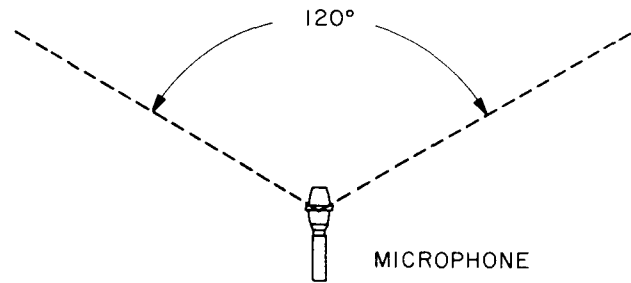

**MICROPHONE ACCEPTANCE ANGLE**  
**FIGURE 5**

**TYPICAL APPLICATIONS**

**Conference Room**

Refer to the AMS Operators Manual for microphone placement at conference tables. Connect extension cables to the microphones and to the microphone input connectors on the rear panel of the mixer. Connect the Line/Mic Output to the line input of the PA amplifier. To record the meeting, connect the Aux Output to the aux input of a tape recorder.

**Church**

Connect extension cables to the microphones and to the microphone input connectors on the rear panel of the mixer. Connect the Line/Mic Output to the line input of the PA amplifier. To record the service, connect the Aux Output to the aux input of a tape recorder [see Figure 6].

Note that the choirs are inside the acceptance angles of the pulpit and lectern microphones. Thus, some choir members may gate on the pulpit and lectern microphones occasionally. This will not seriously degrade the performance of the system.

**Courtroom**

Connect equipment as described for the church setup. Also connect each Direct Output to a separate microphone input channel of a multitrack tape recorder for easy identification of talkers during transcription. The Aux Output containing a mix of all the microphones connects to another channel of the multitrack recorder. This channel can be monitored to hear the entire proceedings. [See Figure 7].

Often a tape playback is used for evidence or for transcript verification. Connect the tape player's aux output to the Aux Input of the mixer.

**Legislature**

A typical legislature setup is shown in Figure 8. [Chairperson-Controlled Muting—see LOGIC FUNCTIONS—is also shown.] Two or more mixers are linked via the Link A and Link B jacks. The Channel 8 Logic Ground ter-

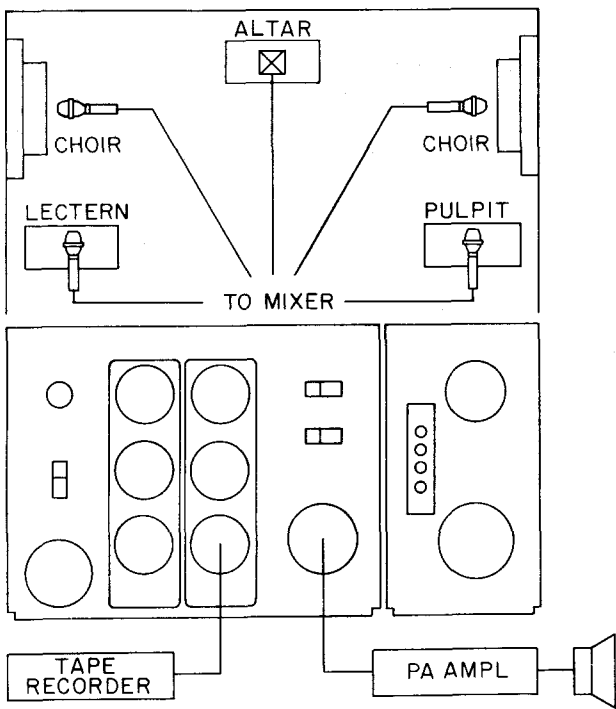

**CHURCH SETUP  
FIGURE 6**

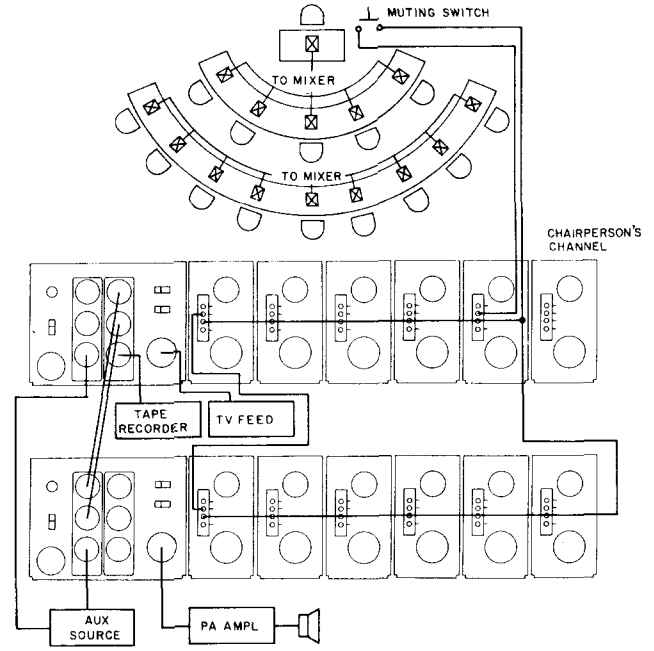

**LEGISLATURE SETUP  
FIGURE 8**

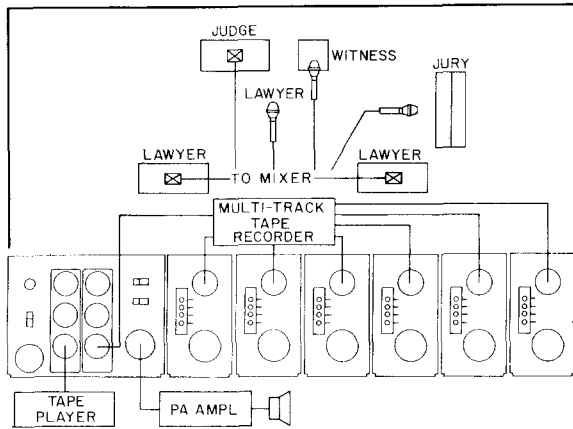

**COURTROOM SETUP  
FIGURE 7**

minals of the linked mixers are connected. One mixer feeds a PA system, and another mixer feeds a tape recorder and equipment for a television broadcast.

Note that the Off-Attenuation can be set differently for the PA mixer than for the TV mixer. The TV feed and recorder may sound more natural if the Off-Attenuation is set at -8 if the room noise is sufficiently low. On the other hand, for highest gain before feedback in the PA amplifier, the Off-Attenuation should be set at -15 or, in some cases, at minus infinity. The Master Gain control is set differently on each mixer to obtain proper levels feeding each system. The aux source control on each mixer may also need to be set differently.

## LOGIC FUNCTIONS

### Cough Button

The user can turn off his or her microphone [to the selected Off-Attenuation level] during coughing or private conversations. To establish this function, wire an SPST pushbutton switch between the Mute In and Logic Ground terminals on each channel requiring a cough button. See Figure 9.

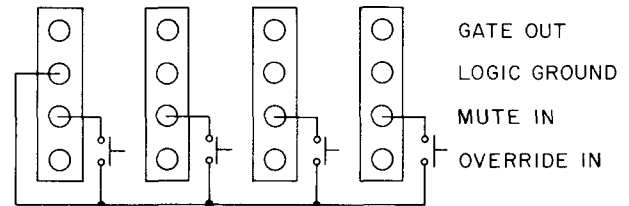

**COUGH BUTTONS  
FIGURE 9**

### Chairperson-Controlled Muting

By activating a switch, the chairperson can silence all the other microphones and be heard without interruption. To establish this function, connect together all the Mute In terminals of all the mixers, but make no connection to the logic terminals of the chairperson's microphone channel. Wire an SPST pushbutton or toggle switch between the Mute In and Logic Ground terminals of any one channel except the chairperson's channel. See Figure 10.

The Chairperson-Controlled Muting feature is also illustrated [see Figure 8] as part of a large system for a legislature. Note that the Logic Ground terminals of both mixers are connected, and that the chairperson's logic channels are unconnected.

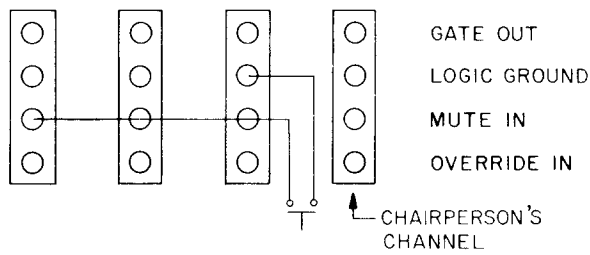

**CHAIRPERSON-CONTROLLED MUTING**  
**FIGURE 10**

**Disabling the Gating Function (Bypass)**

To keep all the microphones on, wire all the Override In terminals together to a Logic Ground terminal [see Figure 11]. This is useful if it is desired to bypass the automatic functioning and use the AMS mixer as an ordinary mixer.

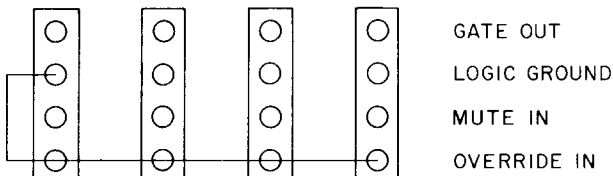

**GATING BYPASS**  
**FIGURE 11**

**Remote Channel-On Indication**

The LED's above each Channel control light when that channel is gated on. These indicators can be used to identify the talker or to indicate to each talker when his or her microphone is on. To provide Channel-On indicators at locations remote from the mixer, connect LED's and a 5-volt power supply to the Gate Out terminals as shown in Figure 12. NOTE: To avoid switching clicks in the audio outputs, do not ground the power supply negative terminal to the audio system ground or rack ground.

**IMPORTANT:** If a single cable is to carry the AMS microphone audio signal and the dc power for the LED, separate shielded pairs **must** be used. Failure to carry the dc power on a shielded pair may result in audible clicking due to capacitive coupling between the dc power lines and the AMS microphone lines.

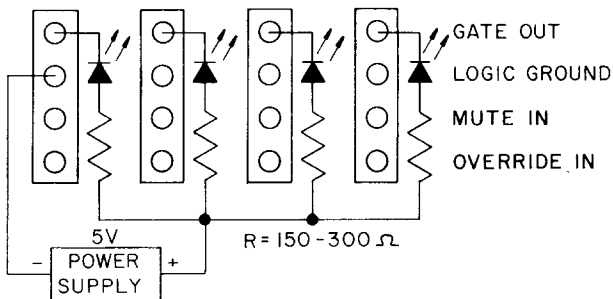

**REMOTE CHANNEL-ON INDICATORS**  
**FIGURE 12**

**Loudspeaker Muting**

In some applications, a loudspeaker is located near each talker to provide audio reinforcement or to allow monitoring of a telephone conversation or conference. Each loudspeaker can cause feedback unless it is automatically switched off whenever the talker near it speaks. To provide this function, connect the Gate Out terminal of each channel to a separate loudspeaker muting relay as shown in Figure 13. Recommended relays are Guardian 1345-1B-12D or 1475-1C-12D, or Potter & Brumfield R50-E2-Y1-12V or R10-E1-Y2-V185, or equivalent.

Each loudspeaker should be placed behind its associated microphone to prevent the loudspeaker from gating on the microphone. The loudspeaker volume should be low; otherwise the microphone may not gate on reliably when the talker speaks.

If the existing sound system uses 24-volt relays, they can be driven with the AMS Gate Out using internal wiring modifications described in the Internal Wiring Modifications section.

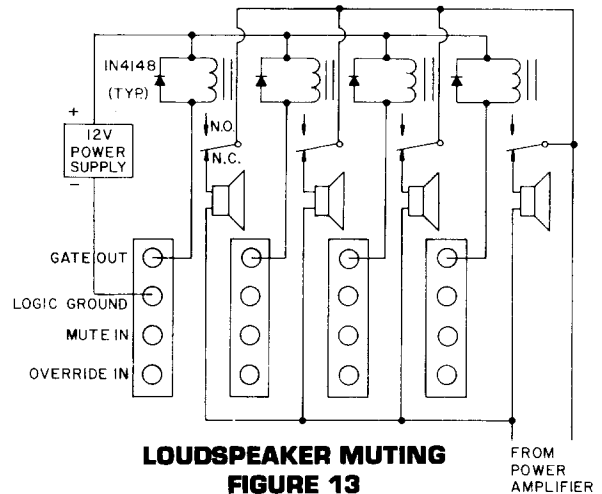

**"Filibuster" Mode**

In normal operation, when several people talk, all their microphones gate on so that no speech is missed. But with the mixer wired for "Filibuster" action, a microphone that is gated on prevents other microphones from gating on. Once a microphone is on, other microphones cannot gate on until the talker has paused long enough so that his or her microphone has gated off. Thus, the person talking has the floor and cannot be interrupted.

To establish this function, perform the internal Mute to Inhibit jumper change [see Internal Modifications section for details]. Then connect all the Mute In terminals of the modified channels together; connect all the Gate Out terminals of the modified channels together, and connect the Gate Out terminal of one modified channel to the Mute In terminal of another modified channel [see Figure 14].

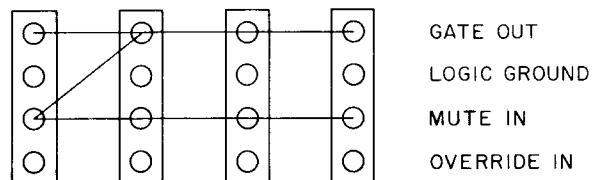

**"FILIBUSTER" MODE**  
**FIGURE 14**



NOTE: To prevent high-frequency oscillation, do not wire a channel's Gate Out terminal to its own Mute In terminal until the Mute to Inhibit change has been made.

### Preventing Room Noise Modulation

This connection keeps at least one microphone on to eliminate varying background noise or "pumping" (see Figure 15). The channel to which the transistor collector is connected will be turned on whenever all other microphones are gated off [see AMS Theory section].

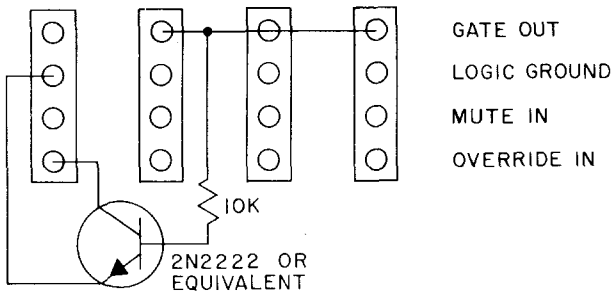

**ROOM NOISE MODULATION PREVENTION  
FIGURE 15**

### Microphone Lock-On

The circuit described in the preceding paragraph can be expanded using diode isolation to perform a new function. Even with the advantages offered by the AMS, there may be installations where it is desirable that the last microphone gated on should remain on until another microphone turns on. For instance, the sound reinforcement requirements of a church may dictate that an altar microphone remain on as the minister moves outside the acceptance angle. Normally the AMS would not remain gated on after the initial hold time elapsed if the minister continued to speak outside the acceptance angle.

With the circuit shown in Figure 16, the last microphone to gate on remains on indefinitely. When a new microphone gates on, it will release the lock-on for the previous microphone, and the new microphone will lock on. The result is the ultimate in automatic mixing: each logic-wired microphone is capable of remaining on until no longer needed. Note that if two or more AMS microphones are simultaneously gated on, normal AMS action will take place. Since at least one microphone is always on, this circuit also prevents room noise modulation. Both the Mute In and Override In remain usable for additional functions.

For each microphone to be given lock-on capability, the circuit uses a 2N2222 general-purpose amplifier NPN transistor (Motorola), a 1-megohm, 1/4-watt resistor, and a number of 1N4148 diodes (GE) equal to the total number of AMS channels involved. For instance, if the installation has five AMS channels to be wired, a circuit containing one transistor, one resistor, and five diodes must be constructed for each channel [a total of five transistors, five resistors, and 25 diodes]. The circuit in Figure 16 shows only **one** lock-on circuit; similar circuits must be constructed for all lock-on channels.

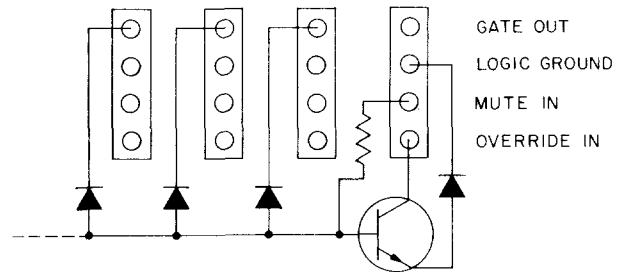

**MICROPHONE LOCK-ON  
(ONE CHANNEL SHOWN)  
FIGURE 16**

### Diode Isolation of Logic Controls

Two or more control functions using the same logic terminals can be isolated with diodes. Here a channel can be muted by an overall group mute switch, or by its own cough button [see Figure 17].

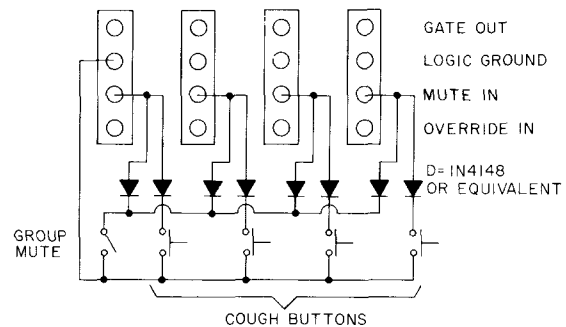

**DIODE ISOLATION OF LOGIC CONTROLS  
FIGURE 17**

### External Logic Devices

The AMS logic levels are directly compatible with TTL and 5-volt CMOS logic families. The following example (Figure 18) uses logic gates to perform the same function as the diode isolation of logic controls. Suggested TTL, LSTTL, or CMOS NAND gates in Figure 18 are 1/2-7420, 74LS20 and 74C20. Suggested AND gates are 7408, 74LS08 and 74C08. In the example, the output of the Channel-On indicator goes to logic High if any channel gates on. [For information on logic gate use, see the **TTL Cookbook** and **CMOS Cookbook**, both by D. Lancaster, Howard Sams Publishing Co.]

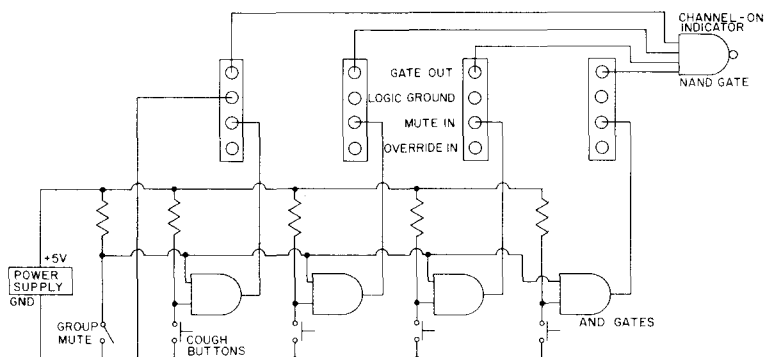

**EXTERNAL LOGIC DEVICES  
FIGURE 18**

### 15-Volt CMOS

The logic terminals can be used with 15-volt CMOS if a pull-up resistor is used with each Gate output [see Figure 19].

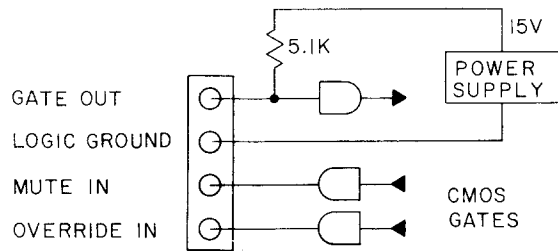

**15-VOLT CMOS  
FIGURE 19**

### Digital Controls or Microcomputers

The AMS mixer logic terminals can interface with custom-designed digital control circuitry or even a microcomputer for unlimited possibilities of system control functions.

### Wireless Microphones

A wireless microphone can be used with the AMS [without automatic gating], but its connection may be made in several ways. If the microphone has a line-level output, connect that output to the AMS mixer auxiliary input. An alternate method is to connect a short jumper between the Logic Ground and Override In logic terminals of the channel that will contain the wireless microphone. With this channel permanently gated on, the balanced microphone-level output of the wireless microphone receiver can be connected to the channel input. [If the receiver has only a balanced line-level output, the same connections can be made, but a line attenuator such as Shure's A15LA should be used in the receiver-mixer line.]

The wireless microphone can be switched on and off remotely by grounding both the Mute In and Override In logic terminals, and putting a switch in the circuit from the Mute In terminal to ground. Since the Mute In circuit has precedence over the Override In circuit, the microphone can be controlled by this in-line switch.

If the wireless microphone receiver has a balanced line-level output, a circuit can be constructed to use the wireless microphone and still retain the automatic gating function. In the diagram shown below [Figure 20], the value of resistor R can be determined as follows. Start with a 2-megohm resistor; at this value, the channel will not gate on until it receives a signal of at least 0.016 volts [-36 dBV]. All AMS logic terminals operate normally with this circuit. The gating threshold can be varied by using a different resistor value according to the needs of the installation. Note that the threshold is raised by a higher resistor value [more voltage is required to overcome the threshold].

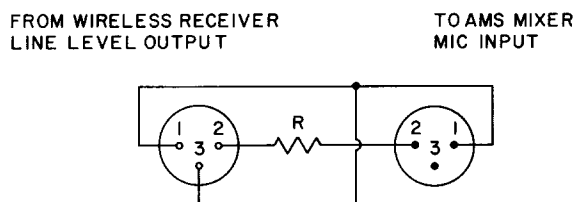

**MICROPHONE INPUT TO GATING LINE INPUT  
FIGURE 20**

### Direct Out Gating

The AMS mixer Direct Out jacks can be converted to direct gated outputs so that the level and equalization of each microphone can be controlled by a studio mixing console. Automatic gain adjustment [based on the number of gated-on microphones] is out of the circuit—the decay time is slightly decreased below the normal 0.3-second interval.

The logic circuit for direct out gating is shown in Figure 21. All resistors are 1/4 watt, and the opto-isolator can be a Vactec VTL5C2 or VTL2C2, or a Shure 86A8900. The 50k to 100k resistor is optional; it will provide a finite Off-Attenuation capability.

Note that if a gated mixed output is not needed for the modified channel, that channel's internal circuitry can be modified rather than using the logic terminals. In this manner, the level control and decay characteristics can be retained, and the need for a separate power supply eliminated. [IMPORTANT: This conversion removes each modified channel from the AMS main mix bus, so that it operates independently of the unmodified channels. In other words, the automatic gating function is retained, but the automatic mixing is not.] Refer to the Internal Wiring Modifications section for further information.

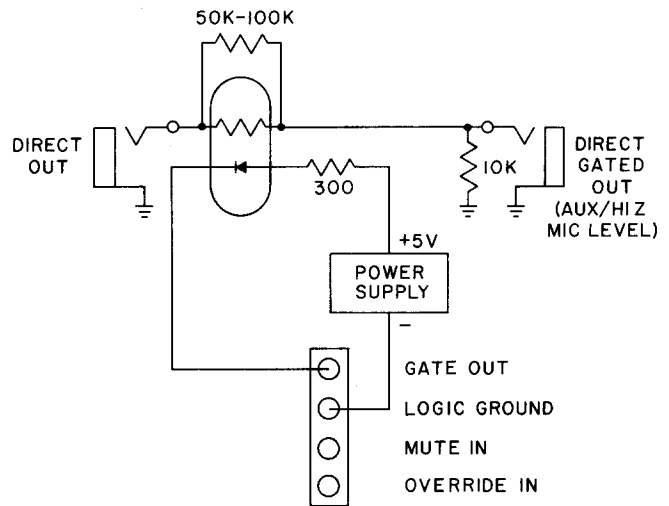

**DIRECT OUT GATING USING LOGIC  
FIGURE 21**

### Controlling Non-AMS Microphones

If it becomes necessary to use a conventional [non-AMS] microphone in an AMS system and the non-gated microphone must be turned off whenever an AMS microphone is gated on, the wiring shown in Figure 22 accomplishes this easily. Connect the non-AMS microphone to the desired input, and other AMS microphones to the other AMS mixer inputs.

Connect the selected channel Logic Ground to its Override In. Wire the Gate Out terminals of the remaining channels together and connect them to the Mute In of the selected channel. Now, whenever an AMS microphone is activated, the Override In and Mute In on the non-AMS microphone channel are grounded, and the Mute In takes precedence.

An external, or "outboard," circuit can also be constructed to use a conventional [non-AMS] microphone with on and off gating. However, it will **not** have some of the primary AMS

microphone features: it will **not** sense ambient room noise, gating will **not** be direction-sensitive, and gating threshold adjustment **will** be necessary. Figure 23 describes the required circuit. Note that [1] microphone-on sensitivity and effective gating threshold are adjusted by potentiometer R5 [level adjustment—but not gating adjustment—is available using the Channel Gain control]; [2] circuit power is supplied by the mixer; [3] a metal enclosure must be used for shielding, and [4] transformer lead P2 is not used.

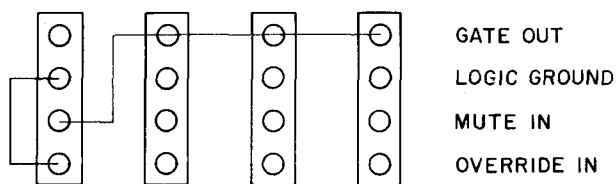

**CONTROLLING NON-GATED MICROPHONES**  
**FIGURE 22**

**OPERATING HINTS**

**Phasing**

Proper microphone cable phasing is essential to AMS operation. If pins 2 and 3 are reversed in a cable for a conventional balanced, low-impedance, microphone-mixer setup, the microphone will still function properly [although with reversed polarity]. But if pins 2 and 3 are reversed in an AMS cable, sounds from the **rear** of the microphone will gate it on. The AMS mixer perceives the microphone's rear as the front and vice versa, and the microphone gates on only if the rear becomes the voice entry. In **all** AMS installations, cable conductors that start out as pins 2 and 3 should end up as pins 2 and 3, respectively.

**Microphone Muting**

To install an at-the-microphone muting switch for an AMS channel **without** using the logic terminals, the required circuit is slightly different from that of a conventional microphone and mixer. Figure 24 shows the required components. All resistors are 1/4-watt, and the capacitor is a metallized polyester film non-polarized type [CDE MMWA05W5-20, Sprague 431P505X9R5]. A low leakage current capacitor like this is needed to avoid

undesirable switching clicks. The switch must be a snap-action type, such as a toggle switch.

The circuit must be housed in a metal enclosure for shielding purposes. The enclosure is grounded to pin 1 of the microphone cable, but must be insulated from accidental second grounding through the enclosure mounting surface. This avoids the formation of a ground loop in the microphone circuit.

**Grounding**

In AMS wiring, avoidance of ground loops is of the utmost importance. Good grounding practices must be followed when using extension cables, junction boxes, and cable snakes.

Each microphone cable shield must be connected to ground **only** at the mixer. For instance, if the shielding shell of an XLR connector is connected to pin 1, and the connector is plugged into a grounded junction box, the cable shield becomes tied to ground at the junction box **and** the mixer. The result may be a considerable amount of hum and rf interference. Good noise rejection is virtually guaranteed by elimination of ground loops.

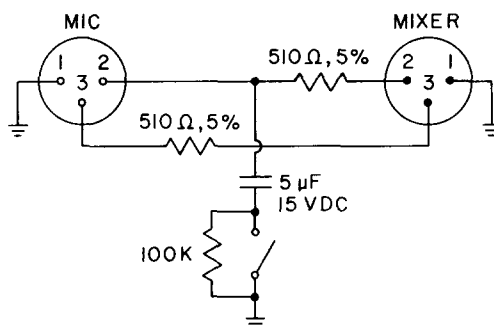

**MICROPHONE MUTING**  
**FIGURE 24**

**INTERNAL WIRING MODIFICATIONS**

This section describes the internal wiring modifications previously mentioned. Refer to the specific application or logic function for detailed information on the purpose of each modification.

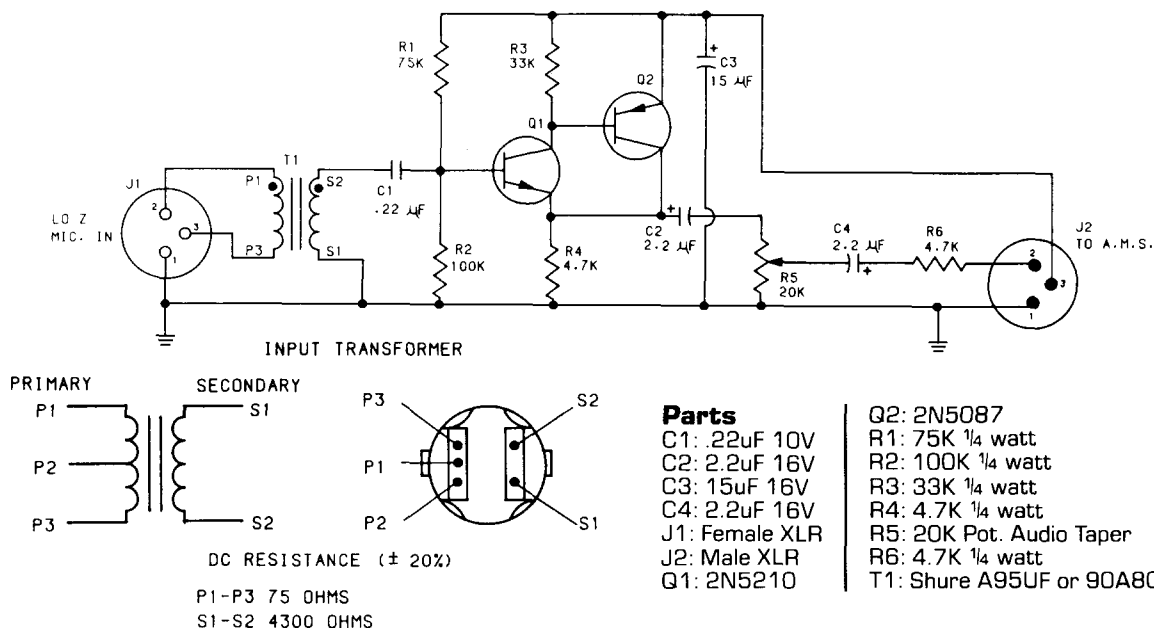

- Parts**
- C1: .22uF 10V
  - C2: 2.2uF 16V
  - C3: 15uF 16V
  - C4: 2.2uF 16V
  - J1: Female XLR
  - J2: Male XLR
  - Q1: 2N5210
  - Q2: 2N5087
  - R1: 75K 1/4 watt
  - R2: 100K 1/4 watt
  - R3: 33K 1/4 watt
  - R4: 4.7K 1/4 watt
  - R5: 20K Pot. Audio Taper
  - R6: 4.7K 1/4 watt
  - T1: Shure A95UF or 90A8032

**NON-AMS MICROPHONE GATING CIRCUIT**  
**FIGURE 23**

## WARNING

No user-serviceable parts inside. Refer all servicing, including modifications, to qualified service personnel.

AMS mixers can be disassembled for modification as follows:

1. Remove line cord from ac power source.
2. Remove screws securing top cover to chassis.
3. Remove individual Channel boards by removing: [a] Channel board bottom screw; [b] Channel Level control knob and nut; [c] Channel-On LED leads; and [d] ribbon cable connector.
4. When replacing Channel boards, be sure to perform steps 3[a] through 3[d] in reverse order.

### 240-Volt Operation

To change the AMS mixer operating voltage from 120 Vac to 240 Vac, follow these steps.

1. Locate the Power board [A5].
2. Remove the transformer T1 plug from connector P501 [marked 120 VAC], and carefully insert it in connector P502, making sure all four pins are properly engaged.
3. Remove the 0.25A/250V fuse from the fuseholder marked F502 and insert the T125 mA/250V fuse [packaged with the AMS mixer] in the fuseholder marked F501.
4. Replace the ac connector with one designed for the 240-volt source. If the mixer is to be used outside the U.S. and Canada, local regulations may require replacing the line cord with one having wire insulation colors as follows:

	"Live" or "Hot"	Neutral	Earth or Ground
U.S., Canada	Black	White	Green
Europe	Brown	Blue	Green/Yellow

5. Mark the rear panel of the mixer with the new operating voltage.

### Hold Time Increase

The 1.0 Sec position of the rear-panel Hold Time switch can be increased to 2 seconds as follows.

1. With the top cover removed, locate the Master board [A2].
2. For AMS4000 mixers, no further disassembly is necessary; for AMS8000 mixers, remove the Channel 8 board as described above.
3. Solder a 30k, ¼ W resistor in the Master board holes marked XR201 [see Figure 25].
4. Reassemble the mixer and mark the Hold Time switch position "2.0" instead of "1.0".

### Pre-Fader to Post-Fader

The Channel Level control can be rewired to **also** control the rear-panel Direct Output level as follows.

1. Remove the top cover and the Channel board to be modified.
2. Locate jumper X101 at the top center of the Channel board, and jumper holes X102 at the bottom center of the board [see Figure 26].
3. Unsolder the jumper at X101 and solder it or a new jumper in the holes of X102.
4. Reassemble the Channel board and top cover as described above.

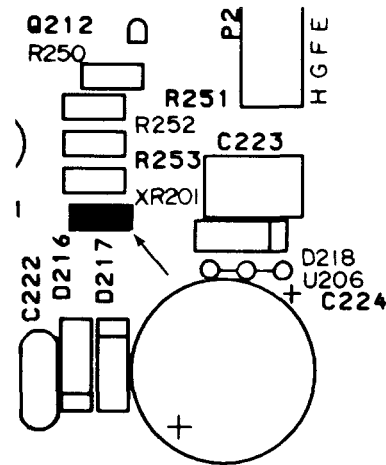

**MASTER BOARD A2: XR201  
FIGURE 25**

### Mute Precedence to Override Precedence

As supplied, if a channel's Mute In and Override In logic terminals are both grounded, the mute function will take precedence over the override function and the channel will be muted. With the following modification [both logic terminals grounded], the override function will take precedence over the mute function and the channel will be forced on. Note that after modification the Channel Level control will still turn the channel off at the full counterclockwise position [independent of the Override IN terminal].

1. Remove the top cover and Channel board to be modified as described above.
2. Locate jumper X104 and jumper holes X103 on the

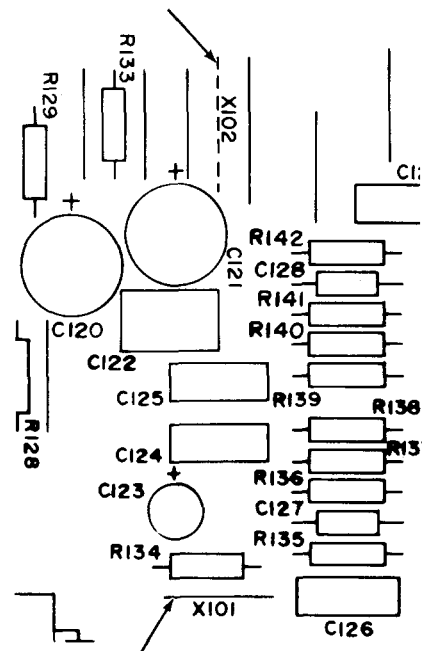

**CHANNEL BOARD A1: X101 AND X102  
FIGURE 26**

Channel board near integrated circuit U105 [see Figure 27].

3. Unsolder the jumper at X104 and solder it or a new jumper in the holes of X103.
4. Reassemble the Channel board and top cover as described above.

### Mute Action to Inhibit Action

As supplied, a channel will mute when the Mute In terminal is grounded. After this modification, grounding the Mute In terminal will not affect the channel if it is already "on", but it **will** prevent the channel from gating "on" from the "off" condition. The modification is required for the "Filibuster" mode previously described, and for any logic terminal use requiring connection of a channel's Gate Out terminal to its Mute In terminal.

1. Remove the top cover and Channel board to be modified as described above.
2. Locate jumper X105 and jumper holes X106 at the bottom front of the board [see Figure 27].
3. Unsolder the jumper at X105 and solder it or a new jumper in the holes of X106.
4. Reassemble the Channel board and top cover as described above.

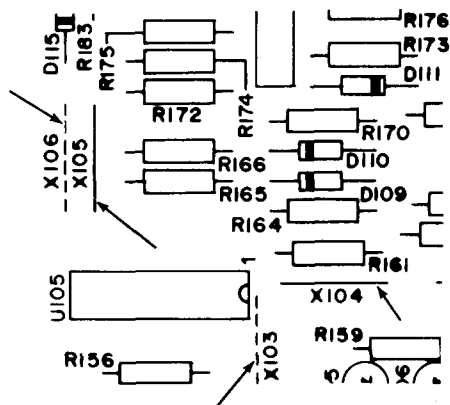

**CHANNEL BOARD A1: X103-X106**  
**FIGURE 27**

### Gated Direct Out

In contrast to the external wiring additions described under Direct Out Gating [see Logic Functions], this modification applies the internal gated microphone signal to the Direct Out Jack while retaining the optimized decay characteristics and avoiding the need for a separate power supply. It does, however, remove the modified channel's gating from the mixed output, and thus does not provide automatic gain adjustment for the number of open microphones.

1. Remove the top cover and the Channel board to be modified as described above.
2. Locate and remove resistor R119 and the wire jumper physically located between R119 and capacitor C118 [see Figure 28].
3. Solder a wire jumper between the hole closest to the printed marking "R119" and the now-empty jumper hole closest to it.

4. Remove resistor R101 [near the Direct Out jack] and replace it with a 5.6k, 5% resistor.
5. Reassemble the Channel board and top cover as described above.
6. NOTE: With this modification, the Direct Out jack now provides a gated signal for that channel only. The signal is high impedance [2.8k to 5.6k] and unbalanced, with a nominal signal level of -24 dBV [60 mV] for 74 dB SPL with the Channel Gain control centered. It will vary directly with the Channel Level control. This is equivalent to a typical aux level signal. To obtain a low-impedance balanced, mic-level output, plug in an impedance matching transformer [Shure A95U or equivalent]. The nominal level then becomes -48 dBV [4 mV].

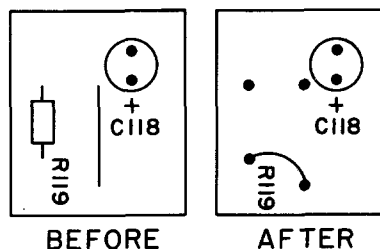

**DIRECT GATED OUTPUT CONVERSION**  
**FIGURE 28**

### Direct Out to Send/Receive Jack

AMS Direct Out jacks can be modified to function as send/receive jacks for use with equalizers, limiters, voltage-controlled amplifiers, or other external devices. With the modification, the microphone output signal is present on the tip terminal of J101, and the return input signal is on the ring terminal. The modified output signal has a nominal level of -37 dBV at 74 dB SPL [17 dB higher than the unmodified Direct Out signal level], with a maximum level of +17 dBV at 128 dB SPL. The patch point is before the Channel Gain control [pre-fader] and before the microphone gating [ungated]. The external device should be a nominally unity gain circuit, with an input impedance of 10k or greater. The load impedance it sees at the ring terminal will be 5k to 10k, depending on the Channel Gain control setting. Consult the processing device manufacturer's literature for proper applications within these level and impedance limits.

1. Remove the top cover and Channel board to be modified as described above.
2. Locate, unsolder and remove resistors R101 and R104 and jumper X107 on the Channel board [see Figure 29].
3. Solder a wire jumper between the X107 solder hole **farthest from the edge of the board** and one of the solder holes **between** the now-removed R101 and R104 resistors.
4. Locate point Z on the Channel board [ring terminal of J101], and solder a jumper between it and the remaining [board edge] solder hole of X107.
5. For circuit continuity when a processing device is **not** connected to the modified Direct Out jack, wire the jack's tip and ring switching terminals together. [These

are the two terminals on the opposite side of the jack body from R101 and R104.) Wiring can be made at the top [component] side of the board, or to the foil side **after** the bottom plate is removed. Note that the jumper should be run **around** the area that will be covered by the bottom plate to assure proper bottom plate fitting. Replace the bottom plate after wiring. Note that a similar effect is obtained by plugging a stereo phone plug with the tip and ring shorted into the Direct Out jack; this must be done if the modified Direct Out jack is to be used as a standard Direct Out jack.

### 24-Volt Relays

To use the AMS Gate Out logic terminal to drive 24-volt relays for loudspeaker muting, each channel must be modified as follows:

1. Remove the top cover and Channel board to be modified as described above.
2. Unsolder and remove diode D113.
3. Reassemble the Channel board and top cover as described above.
4. To prevent circuit damage caused by inductive "kickback" when the relay is de-energized, make certain a diode is placed across the relay coil as shown in Figure 13.

### AMS4000: Input Expansion

Model AMS4000 mixers, supplied with four input channels, can be expanded to accommodate up to eight AMS microphones through the installation of additional Channel boards [RKC188; order one for each additional channel] and

a nine-connector cable [RKC189; one cable provides for up to eight inputs].

1. Remove the top cover as described above.
2. Remove the five-connector cable between the Channel boards, and remove the blank rear plate of each channel to be added.
3. Using the template supplied with the Channel board, drill the front-panel nameplate holes for the LED [0.254" ±0.005"] and Channel Level control [0.296" ±0.005"] for each channel to be added. [NOTE: It is not necessary to drill the front panel for the rectangular locator pin.]
4. Insert the new Channel board from the rear, making sure the rectangular locator pin is properly centered in its mounting hole.
5. Use the supplied nut and washer to secure the level control to the front panel.
6. Secure the new Channel board bottom plate with the screw previously removed.
7. Insert the new Channel-On LED through the front panel [leads first] and use a 3/16" nut driver against the bezel to secure the LED flush with the front panel. Attach the white and red LED leads to the marked terminals at the upper front of the new Channel board.
8. Attach the new nine-connector cable to the Master and all Channel boards [unused channels will have unused connectors].
9. Attach the new Channel Level control knob and replace the cover.

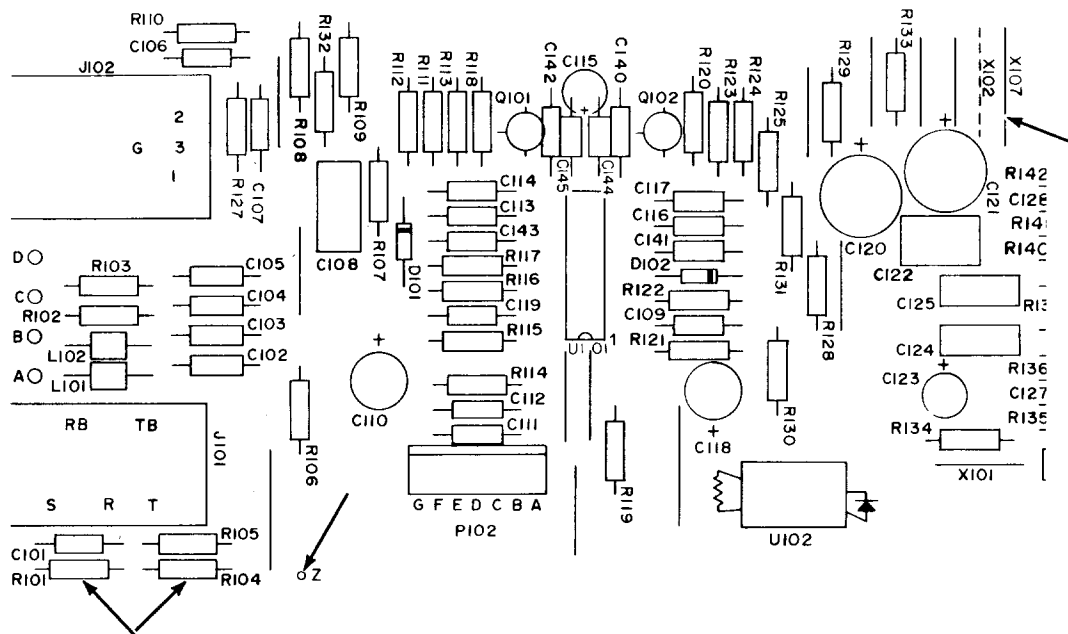

**CHANNEL BOARD A1: X107, R101, R104, "Z"**  
**FIGURE 29**

## TROUBLESHOOTING

Symptom	Probable Cause	To Diagnose or Correct
No sound	<p>Channel control or Master control turned too far down; microphone not connected; mixer not connected to power source; Power switch not on.</p> <p>Defective microphone, cable, channel input module</p> <p>Defective power amp, tape deck, speakers, etc.</p> <p>Defective AMS mixer</p>	<p>Make indicated correction.</p> <p>Listen to headphones plugged into the AMS front-panel Phones jack. To check microphone: replace suspect microphone with another. If there is sound, replace microphone cartridge and PC board assemblies, or return the unit to the Shure Service Department for repair; if there is still no sound, check cable.</p> <p>To check cable: replace suspect cable with another. If there is sound, repair or discard defective cable; if there is still no sound, check input module.</p> <p>To check input module: connect microphone and cable to another channel and follow initial setup procedure. If there is sound, replace or repair defective input module; consult Shure Service Department.</p> <p>If there is sound on headphones but no sound from system, check other components and cables.</p> <p>If there is no sound on headphones, consult Shure Service Department.</p>
Erratic microphone gating	<p>Reflective surface near microphone (closer than 200 to 300 mm — 8 to 12 in.) not including table top for surface-mount models); talker positioned on edge of microphone acceptance angle; excessive steady room noise; defective microphone, cable, or input channel.</p>	<p>If there is a reflective surface near microphone, and neither microphone nor surface can be moved, cover surface with a sound-absorptive material at least 100 mm [4 in.] thick. If talker is on edge of acceptance angle, move microphone or talker. If loud, steady room noise [typically from air-handling equipment] swamps out quiet speech, reduce room noise to reasonable conference levels or reduce talker-to-microphone distance. If none of above, check microphone, cable, channel, and system as in NO SOUND section. Check teleconference equipment for malfunction.</p>
Distorted sound	<p>Master or Channel control set too high; defective microphone, cable, or channel; defective amplifier, recorder or speaker</p>	<p>Check that red Overload LED is not on: if on, turn down Channel or Master control until LED goes out. If overload LED is not on, check whether one or all microphones sound distorted. If only one is distorted, check microphone, cable, and channel as in NO SOUND section. If all microphones are distorted, remove AMS mixer from system, and connect undistorted signal source to system inputs. If final sound is still distorted, check system components and recording level. If final sound is <b>not</b> distorted, consult Shure Service Department.</p>
Microphone gates on for unintended sound	<p>Source is within 120° acceptance angle</p> <p>If source is outside 120° acceptance angle: microphone cable defective or wired out of phase; input module defective</p>	<p>Move source or microphone if possible.</p> <p>Repair or replace cable. If microphone still gates on, check microphone and channel as in NO SOUND section.</p>
Excessive hum from one or more microphones [proper gating may be affected]	<p>Microphone input ground loop</p>	<p>Make sure microphone cable shield and 3-pin connector shells are <b>not</b> connected to earth or grounded metallic objects. Shield ground connection should only be made at AMS mixer input connectors.</p>

## APPENDIX I

### EFFECTS OF ACOUSTIC ENVIRONMENT ON GATING

**Room Noise:** The louder the room noise, the greater the talker's sound pressure level must be at the microphone for it to gate on reliably. Generally this is not a problem because people tend to talk louder in noisy environments. In addition, the sensing circuitry has been equalized to reduce sensitivity to room noise. If room noise is causing erratic gating, instruct the talker to stand or sit closer to the microphone. The quieter the room, the farther the talker can be from the microphone before gating becomes erratic.

Gating action is degraded most by continuous noise [such as from air-moving equipment]. Noises of a transient nature, including outside-acceptance-angle talking, have little interfering action.

**Reverberation:** If the talker is far enough from the microphone so that the sound field at the microphone is diffuse, the microphone will not stay gated on. For example, in highly reverberant environments the microphone may gate on initially for a distant sound source, then gate off when the reverberant sound field builds up.

The less reverberant the room, the farther the talker can be from the microphone before gating becomes erratic. Typically, a source will gate the microphone on reliably up to 2 to 6 meters away [6 to 20 ft], depending on the reverberation time and noise level of the room.

**Talker Distance and Angle:** As the talker moves away from the microphone and his speech becomes weaker in comparison to room noise and reverberation, the acceptance angle for reliable gating narrows.

If the talker speaks just outside the acceptance angle, the microphone will gate on occasionally. It will not gate on at all if the talker is well outside the acceptance angle.

**Reflective Surfaces:** Sound reflections from a hard surface behind the microphone can hamper proper gating. The microphone should be at least 1 meter [3 ft] from a wall behind it, and at least 0.3 meters [1 ft] from objects behind it such as large ashtrays or briefcases. For this reason, do not place the AMS mixer on the table near the rear of the microphones.

Early reflections from nearby walls may trigger occasional microphone gating for sound sources outside the acceptance angle. This is more likely to occur in smaller rooms excited by narrow frequency range loudspeakers. This effect is minor and should not cause any operational difficulty.

Operation on the verge of feedback [ringing], with sustained feedback or with test tones, can be expected to cause some gating due to standing wave patterns in the room.

## APPENDIX II

### THEORY OF THE SHURE AUTOMATIC MICROPHONE SYSTEM

Two problems associated with conventional multi-microphone installations result from unwanted sound pickup from temporarily unused microphones. These microphones contribute excess room noise and reverberation, reducing clarity and intelligibility. They also increase the total gain of a sound reinforcement system, pushing the system close to feedback [howling] and reducing the gain-before-feedback available to individual microphones.

An idealized multi-microphone installation would have the microphones spaced in a uniform, diffuse sound field, and operated at identical effective gains. Under these conditions, the increase in system gain compared to a single microphone is given by:

$$G[\text{dB}] = 10 \log_{10} n$$

n	1	2	4	8	16	32	64	128
G[ $\text{dB}$ ]	0	3	6	9	12	15	18	21

Where G is the system gain increase in dB over a single microphone and n is the number of "on" microphones.

In a sound reinforcement application, total system gain must be adjusted below the feedback threshold with all microphones operating. In a conventional mixing system, each microphone would have G decibels less gain-before-feedback available than it would operating alone. G also represents the increased pickup of room noise and reverberation compared to a single microphone.

A solution to these problems is to gate on only the microphone or microphones immediately in use. The Shure AMS does this effectively and reliably by gating an individual microphone on only in response to a sound source within its acceptance angle. A microphone will not gate on for diffuse room noise and reverberation, or for sound sources outside its acceptance angle. While gated on, the AMS microphone has a standard cardioid [unidirectional] pickup pattern [half- or hemi-cardioid in the surface-mount AMS22].

With multiple talkers, or a talker within the acceptance angle of more than one microphone, a number of microphones may be gated on simultaneously. In a sound-reinforcement application, if the system gain is set below the feedback threshold with a single microphone gated on, the increase in system gain with additional "on" microphones could cause feedback. The AMS prevents this by automatically reducing all "on" microphone gains by at least G decibels as additional microphones are gated on. This maintains constant total system gain, avoiding feedback and permitting the maximum microphone gains at all times.

This constancy of system gain means that pickup of room noise and reverberation also remains constant at the level of a single microphone. Except for transitions between zero and one "on" microphone, gating action does not result in audible modulation ["pumping" or "breathing"] of the room noise. In applications where room-noise modulation caused by the gating action of the first microphone is objectionable [e.g., critical recording or broadcasting], the logic terminals can be used to ensure that at least one microphone is always gated on. An Override In terminal can be used to keep a commonly used microphone gated on. Alternatively, the connection shown in Figure 16 can be used to force one of the microphones on only when all the other microphones are gated off.

As mentioned in the description of the Off-Attenuation controls, partially rather than fully attenuating the "off" microphone makes the gating action significantly less noticeable. However, if insufficient attenuation is used, the increased system gain from the unused but not fully off microphones will result in room noise and feedback problems approaching those experienced with all microphones fully on.



With a single microphone fully "on", the increase in system gain due to incomplete attenuation in the "off" microphones is given by:

$$G'[\text{dB}] = 10 \log_{10} [1 + 10^{\text{Att}/10(m-1)}]$$

Where:  $G'$  is the system gain increase in dB compared to full attenuation,  $\text{Att}$  is the Off-Attenuation in dB, and  $m$  is the total number of microphones.

For an eight-microphone system:

Att[dB]	$-\infty$	-30	-20	-15	-10	-8.5	-5	0
$G'$ [dB]	0	.03	0.3	0.9	2.3	3.0	5.1	9

The recommended setting of -15 provides the benefit of finite Off-Attenuation while degrading available gain-before-feedback by less than 1 dB. The Variable position set to -8 [actually -8.5 dB, fully clockwise] provides very smooth gating in applications where an increase in room noise and degradation of gain-before-feedback of up to 3.0 dB is acceptable. Automatic adjustment of the Off-Attenuation level maintains these relationships when additional microphones are added through the linking of additional units. The  $-\infty$  setting is useful when a muted microphone should be fully off.

The above discussion assumed an idealized installation with all the microphones operated under identical conditions. In practice, of course, the microphones may not be operated at identical gains, and the acoustical environment will vary at different microphone locations. Because of its acoustical location or the need for a higher gain setting, one microphone will usually reach its feedback threshold before the others and will establish the limit on system gain. The AMS will act to prevent an increase in system gain beyond that of the worst-case microphone operated alone.

The formulas previously given in this section, which determine the system gain controlling action, assume random phase relationships among the sound fields at the microphones. The approximation is valid for a large number of microphones, but not for just a few. The sound fields at two microphones will be in phase at some frequencies. The combination of the two microphones will tend to increase system gain by 6 dB at these frequencies, instead of the 3 dB for which the AMS compensates. Feedback can occur at one of these frequencies with the gating on of the second microphone, if the gain and phase criteria for feedback are met. Although unlikely, this possibility should encourage the

installer to check different combinations of "on" microphones before declaring the system to be free of feedback.

### APPENDIX III

#### AMS MIXERS AND CONVENTIONAL MICROPHONES

If a conventional low-impedance microphone is connected to the input of an AMS mixer, that channel will operate like a normal mixer channel with the following exceptions:

1. Normally no gating action will occur; the gate will be permanently off.
2. The channel signal will be (compared to the properly operating AMS channel) somewhat degraded through loss of low-frequency signals (bass rolloff of about 6 dB/octave below 500 Hz), increase in noise, and loss in signal level.

However, the conventional microphone signal **will** be passed **if**:

1. That channel's Level control is sufficiently high.
2. The Master Gain control is sufficiently high.
3. The Off-Attenuation control is **not** set for minus infinity [ $-\infty$ ].

Since the channel remains gated off, the Off-Attenuation control determines the level at which the conventional microphone signal will be passed.

A more desirable method of using an AMS mixer channel with a conventional microphone is to use the Override In logic terminal to force the channel on. In this mode, the microphone signal is typically 15 dB higher than in the gated-off mode. Only the Channel Level and Master Gain controls affect the microphone signal; the Off-Attenuation control does not affect the signal because the channel is gated on. Note that the use of a conventional microphone in one channel will not affect other AMS mixer channels. They will continue to operate properly with AMS microphones.

Many phantom powerable condenser microphones may operate with the low dc voltage supplied by each AMS mixer channel. For instance, Shure's SM85 will operate; however, the microphone's clipping level is significantly reduced because the powering voltage is lower than the minimum rated voltage.

As this section indicates, a conventional microphone **can** be used in an AMS mixer channel. However, it must be noted that signal degradation and loss of all automatic action for that channel are the price paid for not using an AMS microphone.



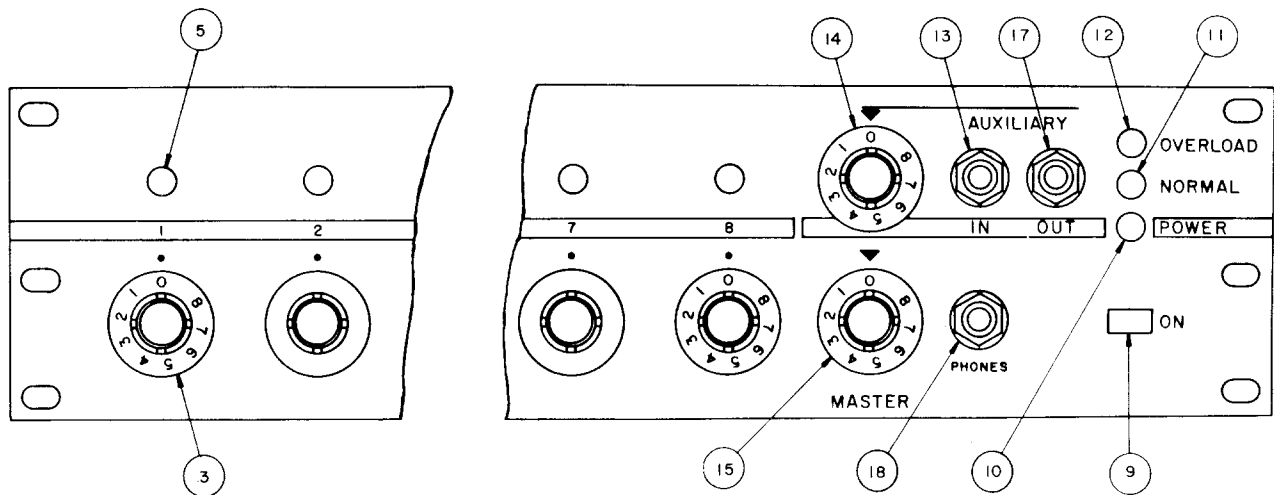

**MODELS AMS4000 AND AMS8000  
FRONT PANEL**

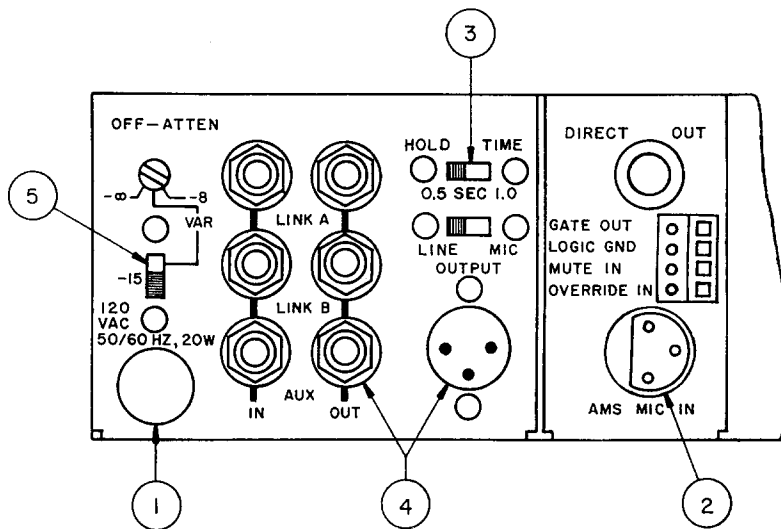

**MODELS AMS4000 AND AMS8000  
REAR PANEL**

**SHURE**

The Sound of Professionals...Worldwide®

**Shure Brothers Incorporated**  
222 Hartrey Avenue  
Evanston, IL 60202-3696 U.S.A.